

CONFIDENTIAL

THIS DOCUMENT AND INFORMATION CONTAINED HEREIN IS PROPRIETARY AND CONFIDENTIAL TO PRECOR STRENGTH INCORPORATED. RECIPIENTS OF THIS DOCUMENT AGREE THAT THIS DOCUMENT AND INFORMATION WILL NOT BE USED FOR ANY PURPOSE, REPRODUCED OR COPIED, OR DISCLOSED TO ANY THIRD PARTY, EITHER IN WHOLE OR IN PART WITHOUT PRIOR EXPRESS WRITTEN PERMISSION OF PRECOR STRENGTH, INCORPORATED.

PRECOR USA
PRECOR STRENGTH, INC.

28936 AVE WILLIAMS
VALENCIA, CA 91355
TELEPHONE: 661-362-0300

SIGN IN BLUE OR BLACK INK ONLY			UNLESS OTHERWISE SPECIFIED: DIMENSIONS ARE IN INCHES		PRODUCT: STRENGTH
DRWN BY	08.15.06	VLE	TOLERANCES ARE: LIN .X=±0.1 .XXX=±0.010 LIN .XX=±0.02 .XXXX=±0.0001 ANGULAR: ±1.0°		
DWG CHK			ALL DIMS AFTER PLATING BREAK ALL SHARP EDGES REMOVE ALL BURRS ALL ANGLES & BENDS 90°* DWG PER ASME Y14.5M-1994 DO NOT SCALE DRAWING ALL MACHINED SURFACES		ASSEMBLY CONNECTION, 10.5
ENG	06.19.06	RSG			
MFG ENG					DWG. NO. CW31874-402
CS					
QA					SUBREV A
ID			SIZE	PAGE OF	
REG			C	1 1	

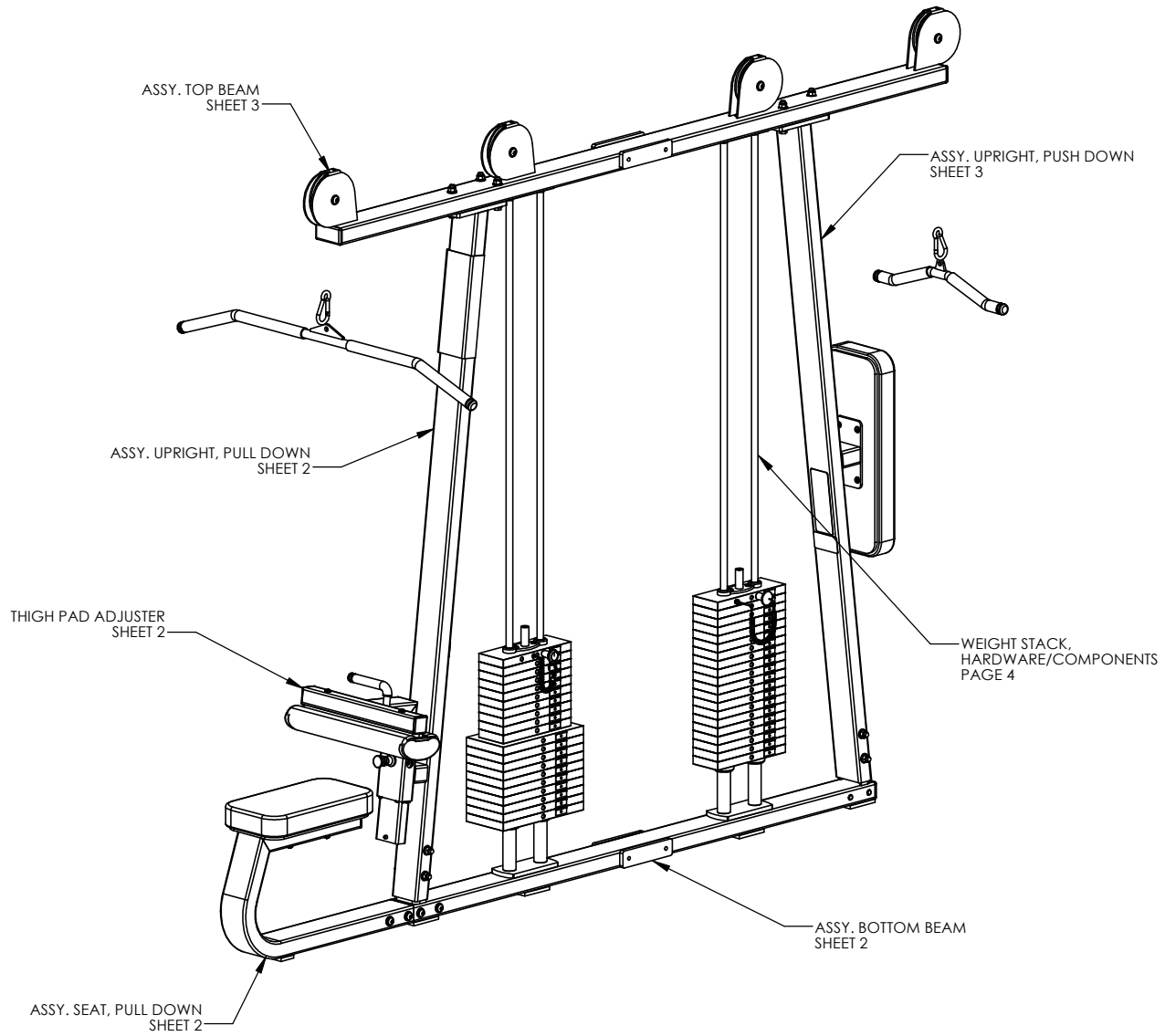

P/N: CW31927-402	SUBREV: E
DRAWN BY: VLE	DATE: 08.18.09
SHEET 1 OF 4	

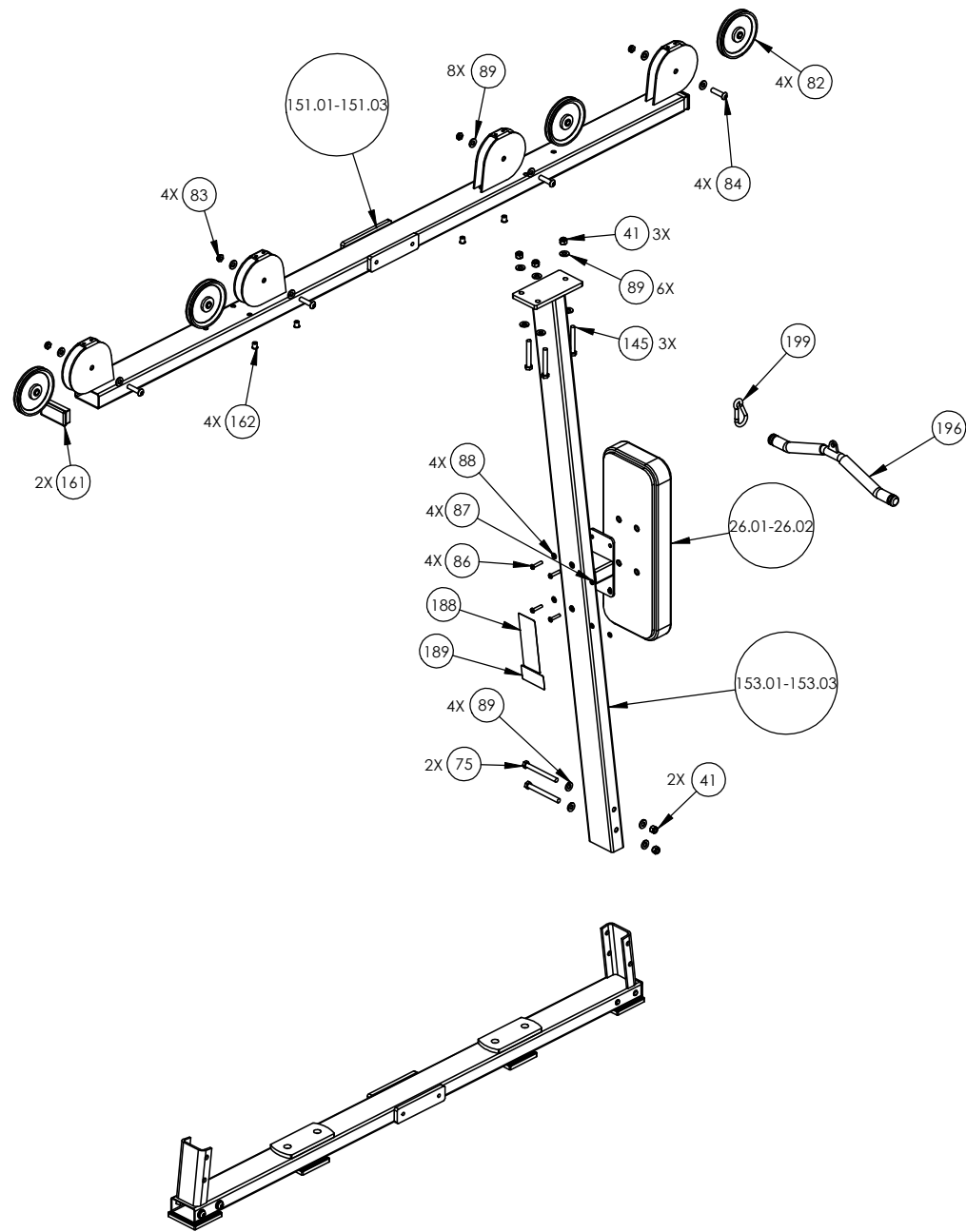

P/N: CW31927-402		SUBREV: E
DRAWN BY: VLE	DATE: 08.18.09	SHEET 3 OF 4

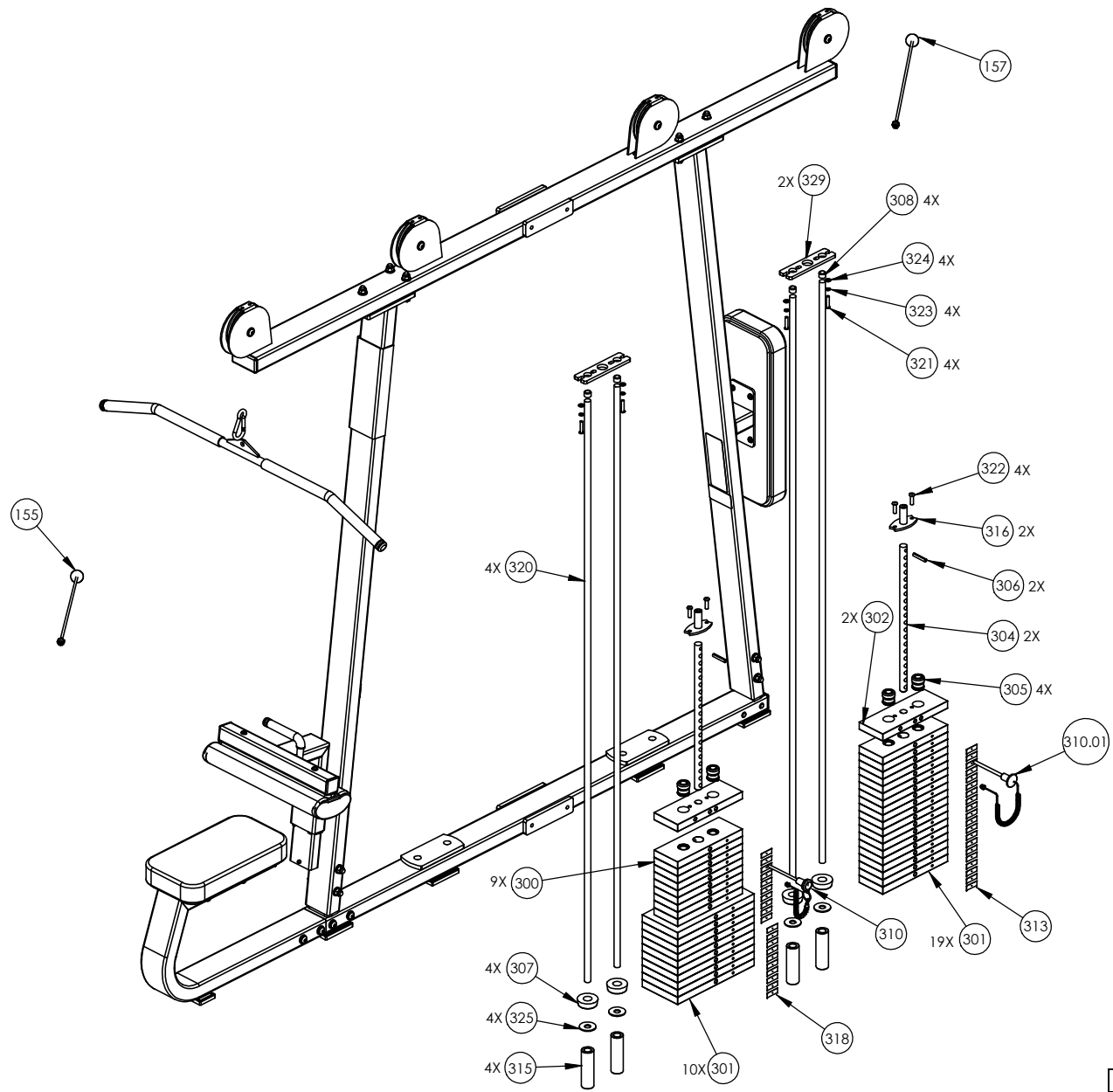

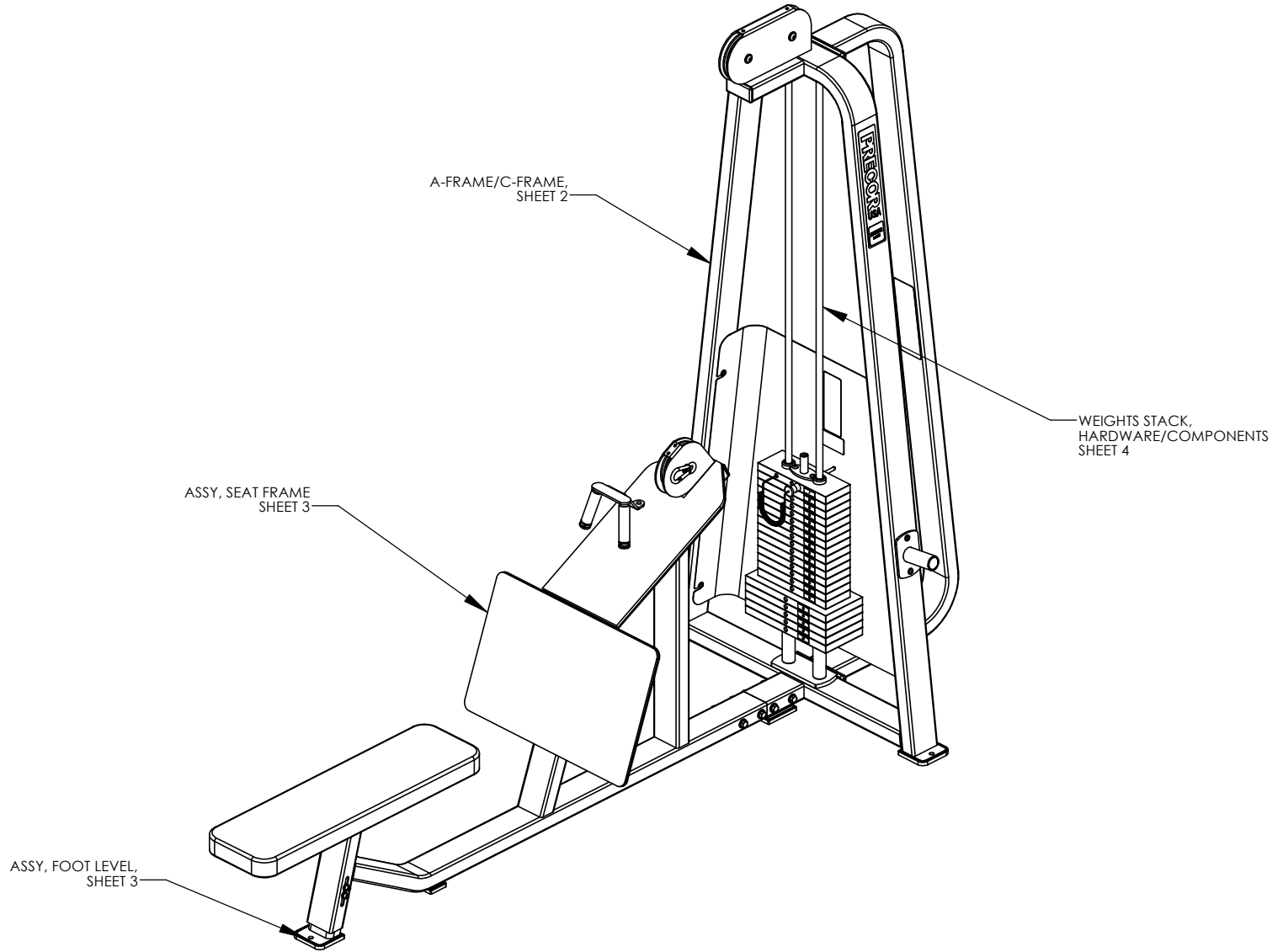

P/N: CW31931-402	SUBREV: C
DRAWN BY: JEC	DATE: 09.11.08
	SHEET 1 OF 4

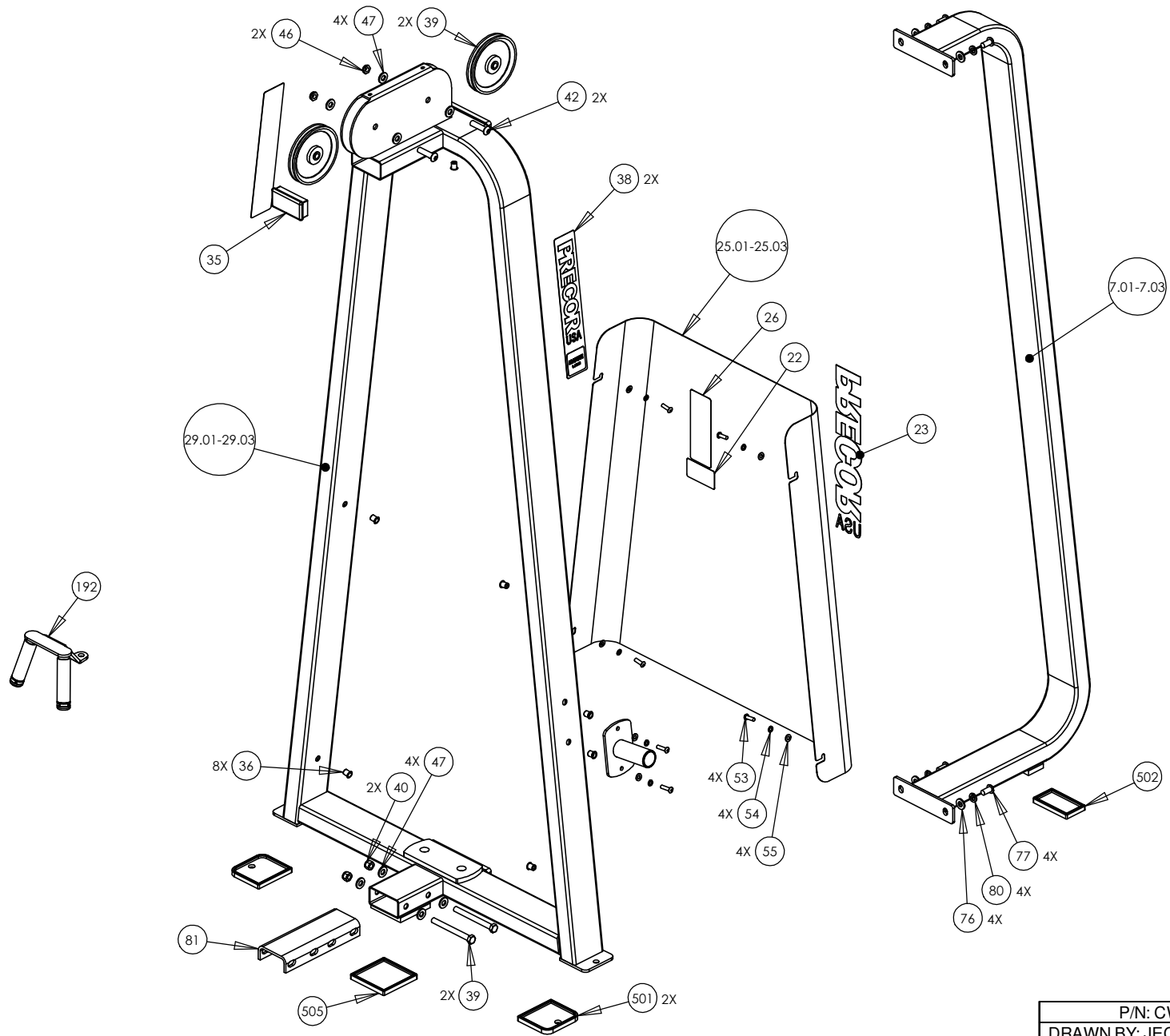

P/N: CW31931-402	SUBREV: C
DRAWN BY: JEC	DATE: 09.11.08
SHEET 2 OF 4	

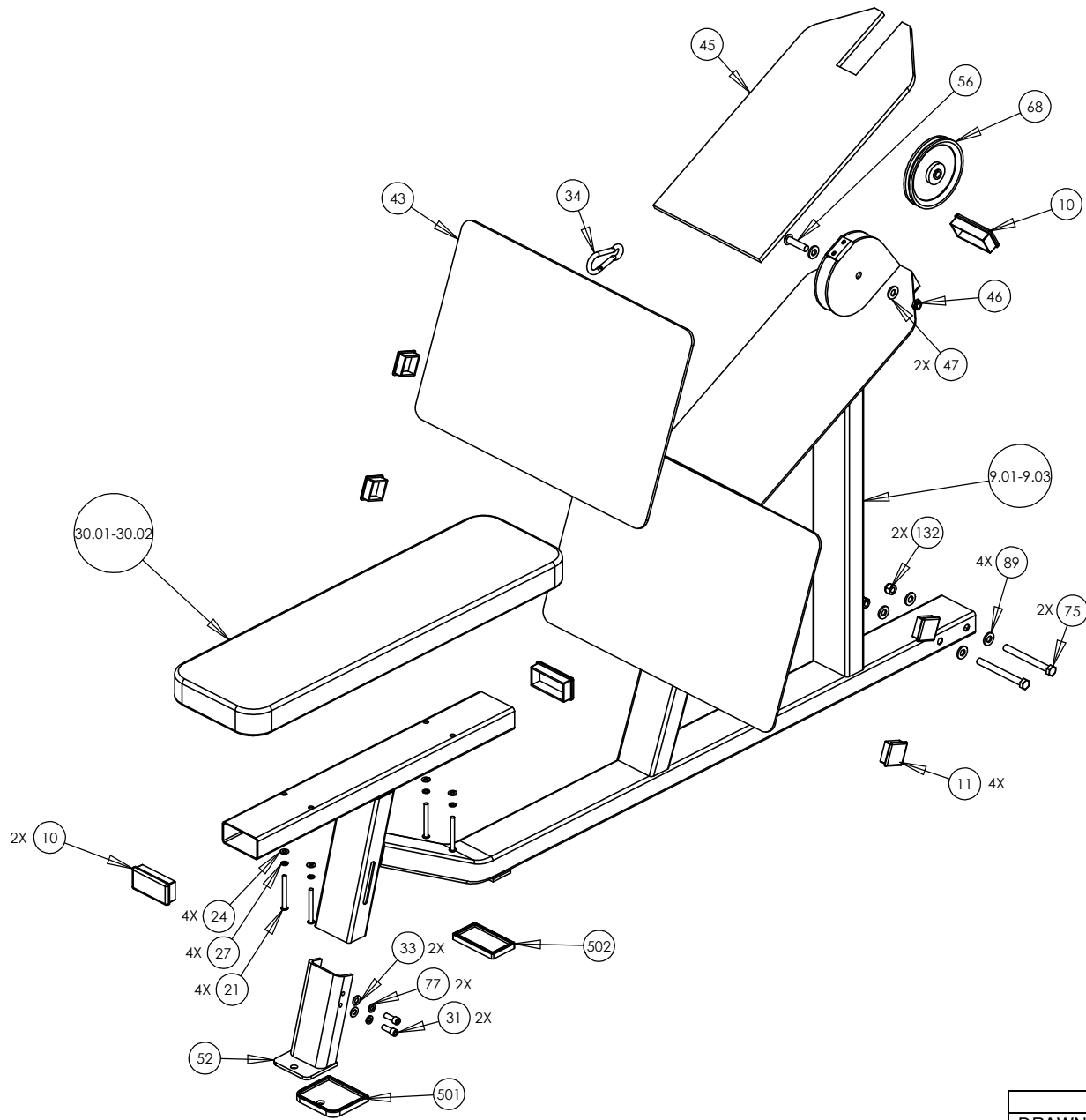

P/N: CW31931-402		SUBREV: C
DRAWN BY: JEC	DATE: 09.11.08	SHEET 3 OF 4

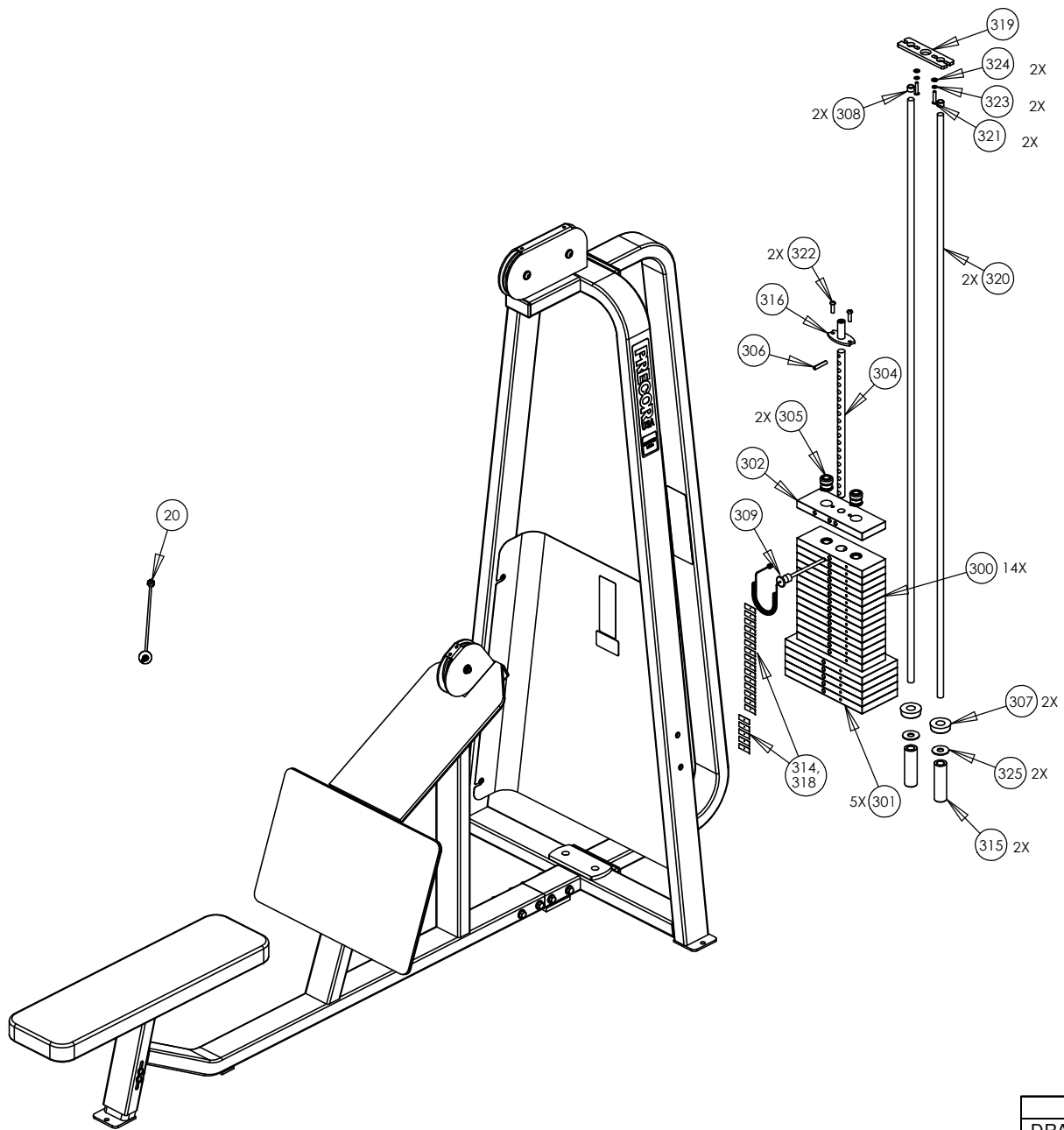

P/N: CW31931-402	SUBREV: C
DRAWN BY: JEC	DATE: 09.11.08
	SHEET 4 OF 4